

ACCU-THERM®
MILK COOLING ANALYSIS
FOR DAIRY FARM APPLICATIONS

Effective September 2, 1984
Revised January 24, 2000

MUELLER®
THE MILK COOLING SYSTEMS SPECIALISTS™

SECTION 1.0 - MILK DEGREE DROP CHARTS

1.1 AT4 Accu-Therm® Milk Degree Drop Chart* (for use with milk pumps up to 50 gpm)

Water Temperature (°F)	Water-to-Milk Flow Ratio		
	½ to 1	1 to 1	2 to 1
AT4DW-21			
50°	17°	24°	28°
60°	14°	19°	23°
70°	10°	14°	20°
AT4DW-31			
50°	19°	26°	31°
60°	15°	21°	25°
70°	11°	15°	19°
AT4DWD-51			
50°	22°	33°	40°
60°	18°	26°	32°
70°	13°	20°	24°
AT4DWD-61			
50°	23°	34°	41°
60°	18°	27°	33°
70°	13°	20°	24°

**Actual degree drop and energy savings may vary depending on field conditions.
Calculations based on 25 gpm milk flow rate entering at 98°F.*

1.2 AT10 Accu-Therm Milk Degree Drop Chart* (for use with milk pumps over 50 gpm)

Water Temperature (°F)	Water-to-Milk Flow Ratio		
	½ to 1	1 to 1	2 to 1
AT10DWD-30			
50°	21°	30°	36°
60°	17°	24°	29°
70°	12°	18°	22°
AT10DWD-40			
50°	22°	32°	38°
60°	17°	25°	31°
70°	13°	19°	23°
AT10DWM-50			
50°	15°	20°	24°
60°	12°	16°	19°
70°	9°	12°	15°
AT10DFM-91			
50°	17°	24°	28°
60°	14°	19°	23°
70°	10°	14°	17°

**Actual degree drop and energy savings may vary depending on field conditions.
 Calculations based on 50 gpm milk flow rate entering at 98°F.
 Degree drop on DFM and DWM models calculated on well water section only.*

1.3 Precooling Degree Drop Chart* Model AT20DFM-71 Well Water Section

Well Water Flow (gpm)	20	30	40	50
Well Water Temp (°F)				
50°	25°	29°	31°	33°
60°	20°	23°	25°	27°
70°	15°	17°	19°	20°
80°	10°	11°	12°	13°

**Actual degree drop and energy savings may vary depending on field conditions. Calculations based on 25 gpm milk flow rate entering at 98°F. Degree drop on DFM models calculated on well water section only.*

1.4 Precooling Degree Drop Chart* Model AT20DFM-101 Well Water Section

Well Water Flow (gpm)	20	30	40	50
Well Water Temp (°F)				
50°	26°	31°	34°	37°
60°	21°	25°	28°	29°
70°	15°	18°	21°	22°
80°	10°	12°	13°	14°

**Actual degree drop and energy savings may vary depending on field conditions. Calculations based on 25 gpm milk flow rate entering at 98°F. Degree drop on DFM models calculated on well water section only.*

SECTION 2.0 - ACCU-THERM ENERGY SAVINGS AND PAY-BACK WORKSHEET

2.1 Present Cooling Cost

- 1. Milk production per day ÷ 1,000 = _____
- 2. Kilowatt hours used per day
(line 1 x 6 kW hrs/1,000 lbs) = _____
- 3. Daily Cooling Cost
(line 2 x kW hrs cost) = _____

2.2 Proposed Savings

- 4. Accu-Therm Degree Drop
(from degree drop chart) = _____
- 5. Percent Run Time Reduction
(line 4 ÷ 60°) = _____
- 6. Estimated Daily Savings:
(line 5 x line 3) = _____
- 7. Yearly Savings
(line 6 x 365 days/year) = _____

2.3 Pay-Back Period

Installed Cost _____ ÷ Yearly Savings _____ = _____

2.4 Return on Investment

Installed Cost _____ ÷ Yearly Savings _____ = _____

NOTE: Milk flow rate based on 15-20 gpm milk pump. Actual degree drop and energy savings may vary depending on field conditions.

SECTION 3.0 - ACCU-THERM MODELS

3.1 Accu-Therm Wall-Mount Models

Part Number	Model	Number of Plates	Shipping Weight (lbs)
Single Pass			
9816135	AT4DW-21	21	85
9816136	AT4DW-31	31	95
Dual Pass			
9816137	AT4DWD-51	51	110
9816138	AT4DWD-61	61	120
9816144	AT4DWD-30	30	245
9816145	AT10DWD-40	40	263
Multi-Pass, Multi-Duty*			
9816146	AT10DWM-50	50	284

**For use with well water and chilled water.*

3.2 Accu-Therm Floor-Mounted Models

Part Number	Model	Number of Plates	Shipping Weight (lbs)
Multi-Pass, Multi-Duty*			
9816148	AT10DFM-91	91	530
9816376	AT20DFM-71	71	1,345
9817914	AT20DFM-101	101	1,515
9830039	AT40DFM-117	117	4,296

**For use with well water and chilled water.*

NOTES:

- (1) Accu-Therm plate heat exchanger performance data for units not listed above are available upon request.
- (2) Multiple-pass and larger plate heat exchangers for instant cooling also available upon request.

SECTION 4.0 - ACCU-THERM PLATE HEAT EXCHANGER SPECIFICATIONS

4.1 All Models

- a. Comply with 3A standards
- b. 304 stainless steel end frames
- c. 316 stainless steel plates
- d. Stainless steel compression bolts with brass nuts

4.2 AT4DW - Wall Mount

- a. Milk pumps to 50 gpm
- b. Water flow to 50 gpm
- c. 1½" clamp-type fittings for milk connections
- d. 1" stainless steel male pipe thread for water connections
- e. Length: 12.0 inches
- f. Width: 7.3 inches
- g. Height: 22.9 inches
- h. Maximum number of plates: 61
- i. Available in dual-pass units

4.3 AT10DW - Wall Mount

- a. Milk pumps to 100 gpm
- b. Water flow to 100 gpm
- c. 2" clamp-type fittings for milk connections
- d. 2" stainless steel male pipe thread for water connections
- e. Length: 16.0 inches
- f. Width: 10.8 inches
- g. Height: 32.6 inches
- h. Maximum number of plates: 40
- i. Available in dual-pass and multiple-pass units

4.4 AT10DF - Floor Mount

- a. Milk pumps to 100 gpm
- b. Water flow to 100 gpm
- c. 2" clamp-type fittings for milk connections
- d. 2" stainless steel male pipe thread for water connections
- e. Length: 30.2 inches
- f. Width: 10.8 inches
- g. Height: 41.0 inches
- h. Maximum number of plates: 91
- i. Available in multiple-pass units for precooling and instant cooling

4.5 AT20DF - Floor Mount

- a. Milk pumps to 200 gpm
- b. Water flow to 200 gpm
- c. 2" clamp-type fittings for milk connections
- d. 2" stainless steel male pipe thread for well water connections
3" stainless steel male pipe thread for chilled water connections
- e. Length: 40.0 inches
- f. Width: 16.3 inches
- g. Height: 49.0 inches
- h. Maximum number of plates: 101
- i. Multiple-pass unit for precooling and instant cooling

4.6 AT40DF - Floor Mount:

- a. Milk pumps to 300 gpm
- b. Water flow to 400 gpm
- c. 3" clamp-type fittings for milk connections
- d. 2" stainless steel male pipe thread for well water connections.
- e. 4" stainless steel male pipe thread for chilled water connections
- f. Length: 126.0 inches
- g. Width: 28.0 inches
- h. Height: 75.0 inches
- i. Maximum number of plates: 117
- j. Multiple-pass unit for pre-cooling and instant cooling.

SECTION 5.0 - DIAGRAMS

5.1 Typical Water and Milk Piping

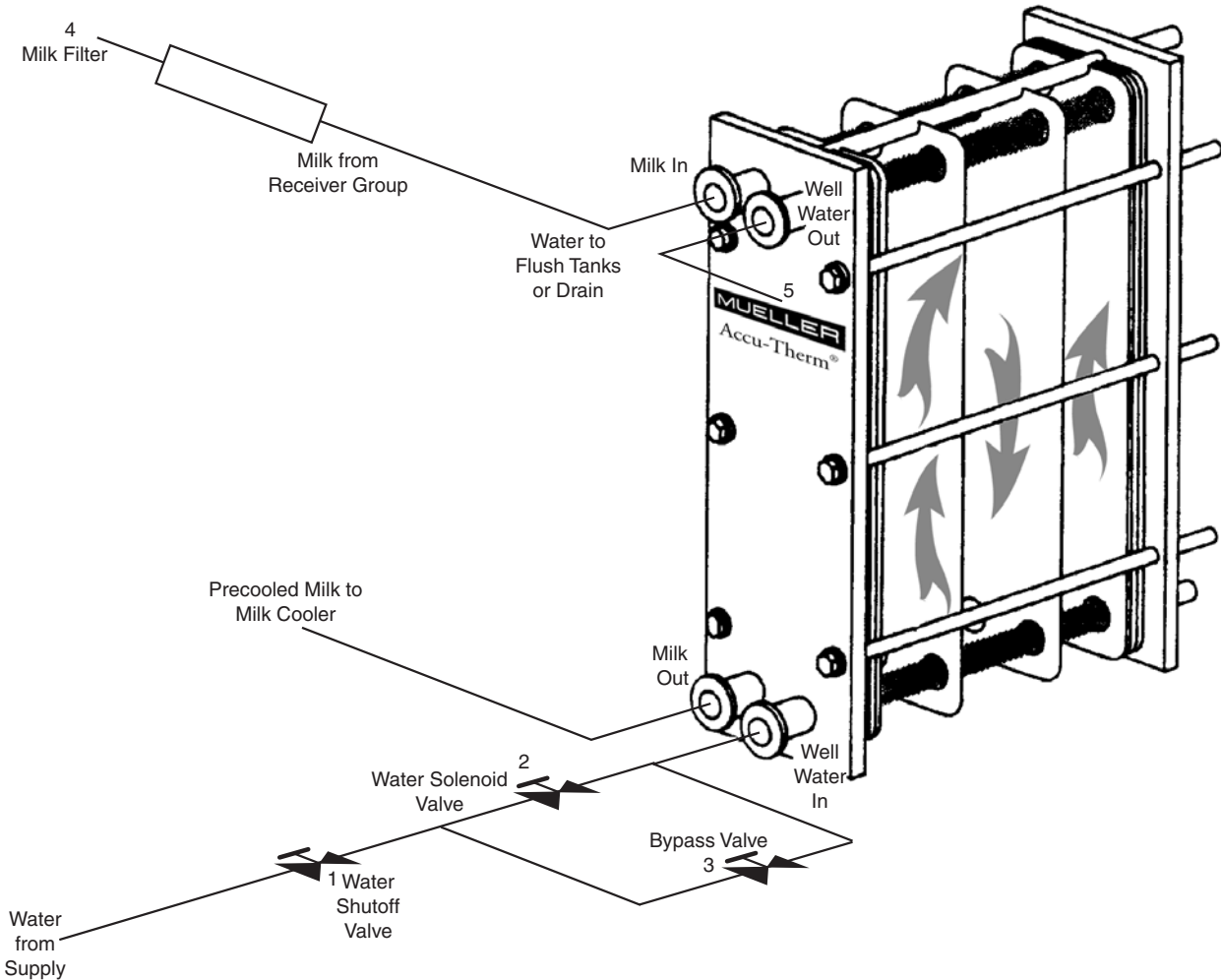

- 1— Water Shutoff Valve. To be open only during milk flow. This valve must be closed during wash cycle.
- 2— Water Solenoid. Wired to operate simultaneous with milk receiver pump.
- 3— Bypass Valve. Allows water to bypass during off cycle of milk pump.
- 4— Milk filter must be installed in the milk inlet before Accu-Therm. Both milk and wash cycles must be filtered.
- 5— Well water out must be connected to meet local and federal sanitation regulations and guidelines.

5.2 Typical Installation for Heating CIP Wash Water During Wash Cycle

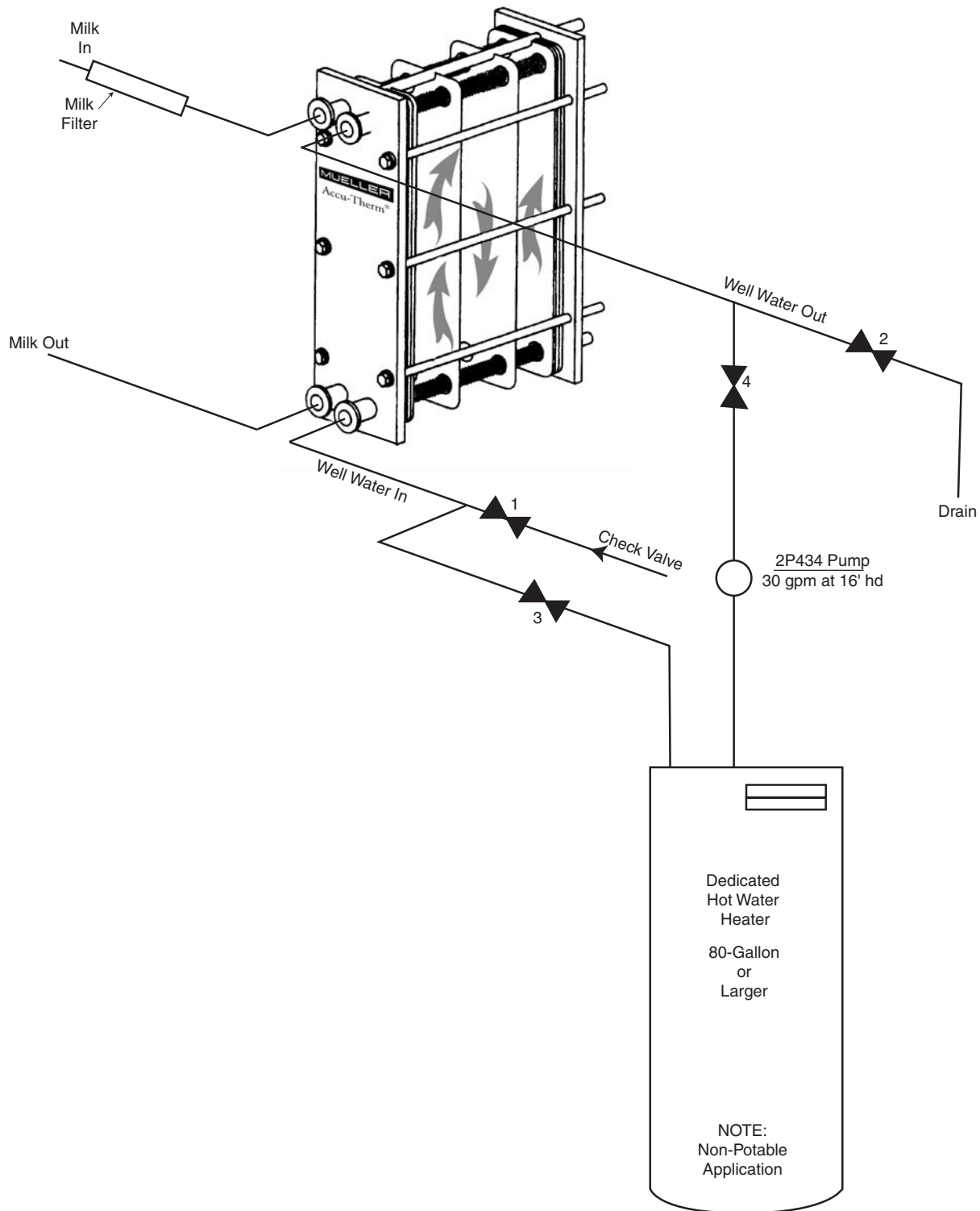

1—During milking, open valves 1 and 2. Valves 3 and 4 should be closed.

2—During wash cycle, close valves 1 and 2 and open valves 3 and 4.

3—Piping must meet local and federal sanitation regulations and guidelines.

MUELLER®

P.O. Box 828 • Springfield, Missouri 65801-0828, U.S.A.
Phone: (417) 831-3000 • 1-800-MUELLER • Fax: 1-800-436-2466
www.muel.com • E-mail: dairyfarm@muel.com